

PROJECT:

Pallet rocking chair

DESIGNER: Mike Harvey, Pre-registered SGD Member



In this occasional series, we take a closer look at an element of garden design and ask the designer to describe the conceptual and practical considerations behind it

WHEN DESIGNING 'Summer in the Garden' for the RHS Hampton Court Palace Flower Show in 2012, I wanted the garden to have a Mediterranean feel and to be somewhere to relax. The chimney was to be the garden's main focal point with a patio in front surrounded by scented planting. There would be seating on the patio but the main problem was making sure the furniture didn't detract from the fireplace. As the garden was to relax in I wanted comfortable chairs that looked right in the 6m x 9m plot, but I felt that standard garden chairs or sofas did not really suit the other materials I had chosen.

In our yard, we had a stack of old pallets of varying colours and I decided to try to use the wood in them to make the furniture. We were on a tight budget and making them ourselves out of scrap wood seemed a good way forward.

I decided on rocking chairs as they are slightly more unusual in gardens and

fitted the combination of old-fashioned materials – crazy York stone paving for the path and patio – with the more modern bright yellow rendered walls. I had already decided on the idea of texturing the wall render with parallel grooves and this gave me the idea of continuing this theme by stacking the different coloured slats of pallets to make the sides of the chairs. We then used the larger support timbers of the pallets to make the seat and back rest.

It took me an incredibly frustrating day to dismantle and de-nail 20 pallets in preparation for our carpenter Nick to make the chairs. The stacked slats were both glued and screwed for strength. All the timber used to make the chairs came from old pallets and you will see from the dimensions of the chairs that they are quite big. I wanted them to make a statement in the garden and as I am 6ft 6in tall I thought it would be good to design something that fitted me!

Budget: Nil **Carpenter:** Nick Ralph of Arun Landscapes

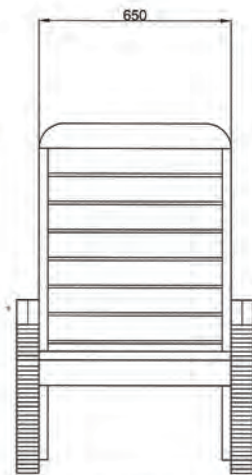

Front elevation

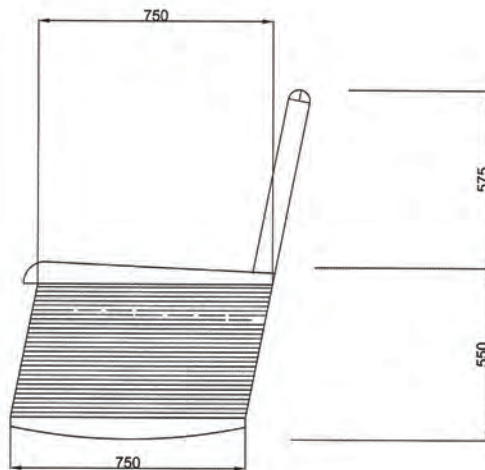

Side elevation

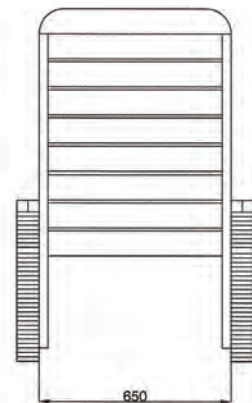

Back elevation

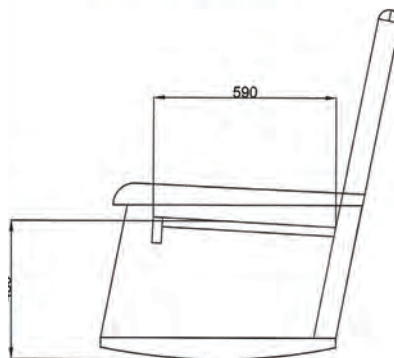

Side elevation

1. Plans for the rocking chairs
2. Bespoke large-scale seating was needed to blend with the show garden's materials
3. The chairs complemented the fireplace
4. The textured sides matched the wall's parallel grooved rendering
- 5 & 6. Different coloured slats from pallets made up the sides of the chairs, while the support timbers were used for the seat and back rest

"In our yard, we had a stack of old pallets of varying colours and I decided to try to use the wood in them to make the furniture"



Share a design detail in *GDJ*

If you have had to tackle a tricky or unusual individual element in one of your designs, we'd like to hear about it – perhaps a walkway, water feature, small building, play area or seating. We'd need to see five or six high-resolution images, a plan or drawing, detailed specifications and/or a construction drawing, plus around 500 words explaining how and why the design was planned and built. Contact us at gdj@jppublishing.co.uk

